

Form No.
908183
Replaces
908037

RL20DX

Rigid Loader



PARTS MANUAL

GEHL® CONSTRUCTION

Introduction

When ordering service parts, specify the correct part number, full description, quantity required, the unit model number and serial number. For your safety and continued proper operation, use only genuine GEHL service parts.

The model and serial numbers for this unit are on a tag located on the lower right control panel. On earlier models, the model and serial numbers for this unit are on a tag located on a panel behind the right rear wheel. “Right” and “left” are determined from a position sitting on the Seat and facing forward. From this position, the connections for the Auxiliary Hydraulics is on the “left” and the Accelerator is on the “right”.

GEHL® Company reserves the right to make changes or improvements in the design or construction of any part of the unit without incurring the obligation to install such changes on any previously delivered units.

NOTE: *On original tire replacement, company policy prohibits the sale of replacement tires for all GEHL machinery. Replacement Wheel Sets are available and tire size information is called out with the Wheel Sets to facilitate replacement tire selection. ALL REPLACEMENT TIRES MUST BE PURCHASED LOCALLY.*

Refer to the abbreviations table located on this page for the various fastener descriptions. Standard attaching hardware torque values are also provided on the inside back cover.

In the exploded view parts list, Reference Numbers may have additional information following the Reference Number.

Unless otherwise specified, all Cap Screws or Bolts are Grade 5, cadmium or zinc plated; Hexagon Nuts for Grade 5 Screws or Bolts are Grade B; Hexagon Nuts for other Screws or Bolts are Grade A.

NOTE: *The following abbreviations may be used herein:*

CP	– Cotter Pin
CS	– Cap Screw (Hexagon Head)
FHCS	– Flat Head Cap Screw
HN	– Hex Nut
LN	– Lock Nut
LT	– Left Hand
M	– Metric
MM/mm	– Millimeter
RT	– Right

TABLE OF CONTENTS

Introduction	Inside Front Cover
Table Of Contents	1
Decal Locations	2-3
Frame, Seat, Wheel & Boom	5
Frame	6-7
Engine	8-9
Loader Boom	10
Transmission	11
Foot Throttle	12
Parking Brake	13
Hydraulics	14-15
Alphabetical Index	16
Numerical Index	17-19
Standard Hardware Torque Specifications	Inside Back Cover

DECAL LOCATIONS

GENERAL INFORMATION

Decal location information is provided to assist in the proper selection and application of new decals, in the event the original decals become damaged or the machine is repainted. Refer to the listing for the illustration reference number, part number, description and quantity of each decal provided in the kit. Refer to the appropriate illustrations for replacement locations.

To insure proper selection of the correct replacement decals, compare all of the various closeup location drawings to your machine before starting to refinish the unit. Then circle each shown decal (applicable to your machine) while checking off its part number in the listing. After you have verified all the decals needed for replacement, place any extra unnecessary decals aside for disposal.

NOTE: Refer to the *SAFETY* chapter of the *Operator's Manual* for the specific information provided on all of the various safety decals furnished in the decal kit(s).

NEW DECAL APPLICATION

Surfaces **MUST** be free from dirt, dust, grease and other foreign material before applying the new decal. To apply, remove the smaller portion of the decal backing paper and apply this part of the exposed adhesive backing to the clean surface while maintaining proper position and alignment. Peel the other portion of the backing paper off slowly while applying hand pressure to smooth out the decal surface.

PAINT NOTICE	
Use this list to order paint for refinishing:	
906213	One Gal. Construction Yellow
906323	One Qt. Charcoal Grey
906317	One Gal. Charcoal Grey
906214	6 (12 oz. Spray Cans) Yellow
906318	6 (12 oz. Spray Cans) Grey

The decal kits for the three loader models are listed below:

Ref. No.	Part No.	Description & Quantity
	155747	Decal Kit - RL14D
	155748	Decal Kit - RL20D
	155749	Decal Kit - RL20DX
1	L65922	IMPORTANT – Operator's Manual
2	156306	DANGER – Personnel Lift
3	093367	WARNING - Owner's Responsibility
4	093474	WARNING - General Safety Precautions
5	093476	WARNING - Fasten Seat Belt
6	114316	IMPORTANT – Starting
7	122718	WARNING – Attachment Lock Pin
8	129132	DANGER – Lift Arm Lock
9	132139	Tiedown Location (4 Places)
10	145216	Red Reflector (2 Places)
11	155724	GEHL (4 Places)
12	155729	AVANTAGE (2 Places)
13	155725	RL14D (2 Places)
	155726	RL20D (2 Places)
	155728	RL20DX (2 Places)
14	156137	Dashboard



CAUTION

ALWAYS follow safety precautions on decals. Replace the decals if they are damaged, or if the unit is repainted. If repainting, **BE SURE** all applicable decals are affixed to your unit.

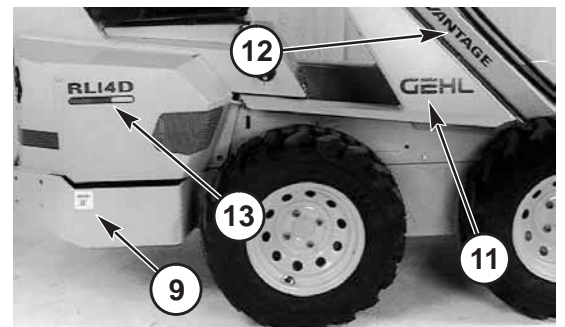
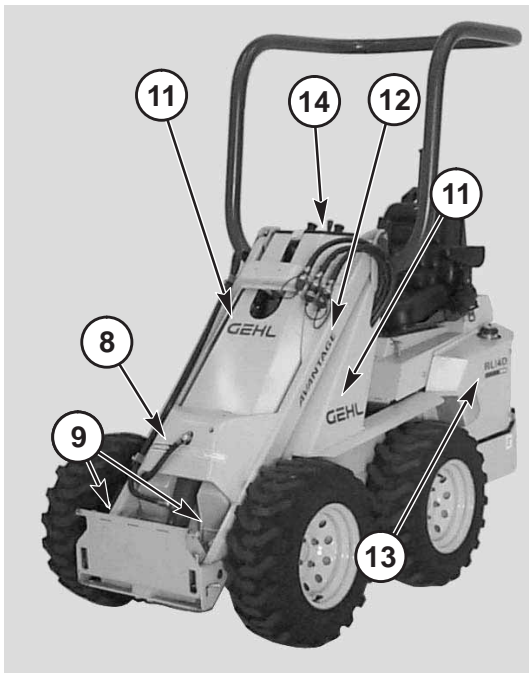
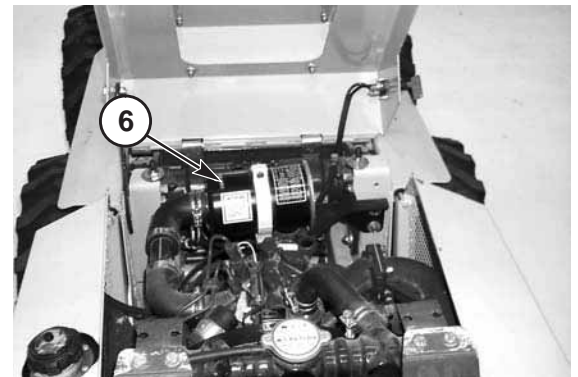
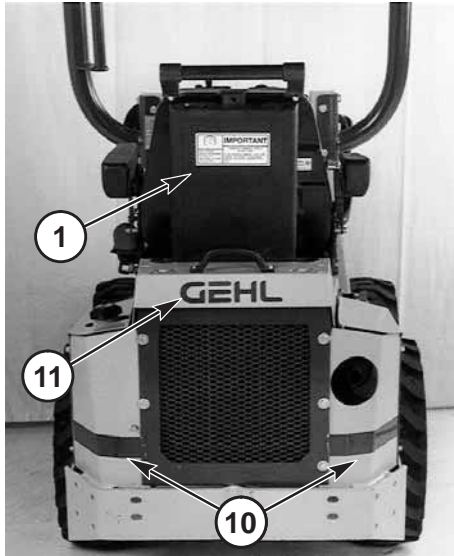
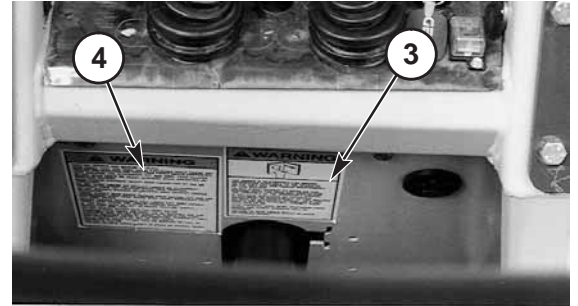
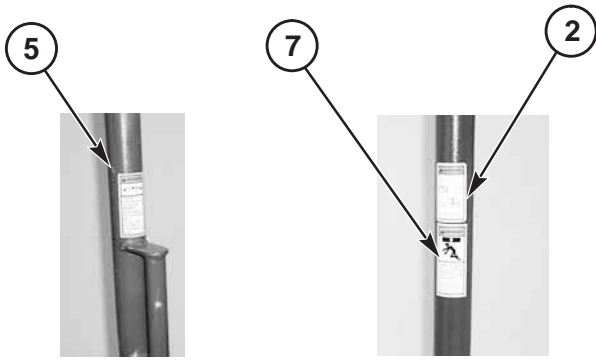

INTENTIONALLY BLANK

RL20DX - FRAME, SEAT, WHEEL & BOOM

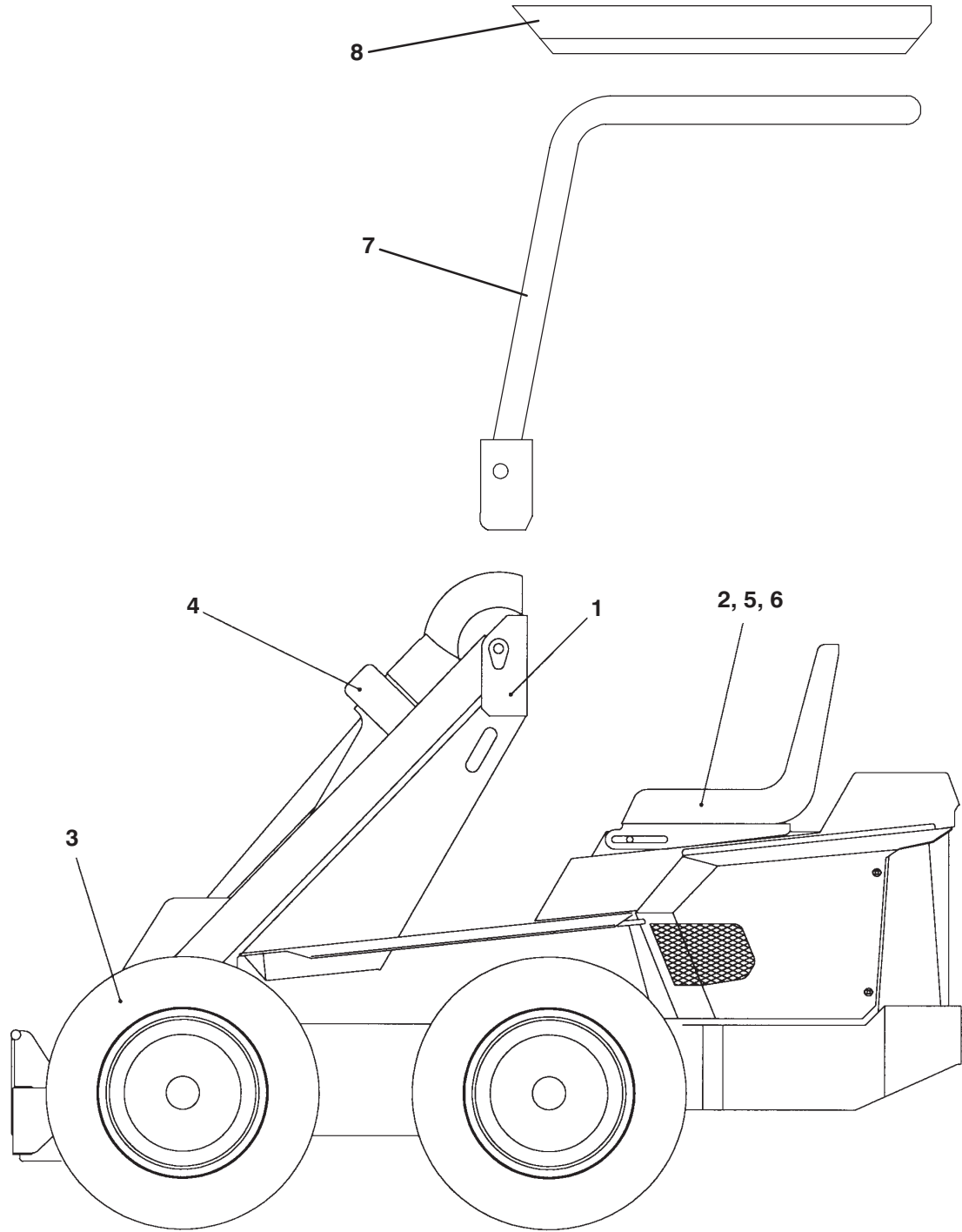

Ref. No.	Part No.	Description	Qty. Req.	Ref. No.	Part No.	Description	Qty. Req.
01	155298	FRAME (RL20D, RL20DX)	1	05	154916	CS M8-16	4
02	154807	SEAT	1	06	154922	WASHER M8	4
03	154815	WHEEL (RL20D, RL20DX)	4	07	156320	ROPS/FRAME	1
04	154958	BOOM/LOADER	1	08	156321	FOPS/ROOF (OPTIONAL)	1

RL20DX - FRAME

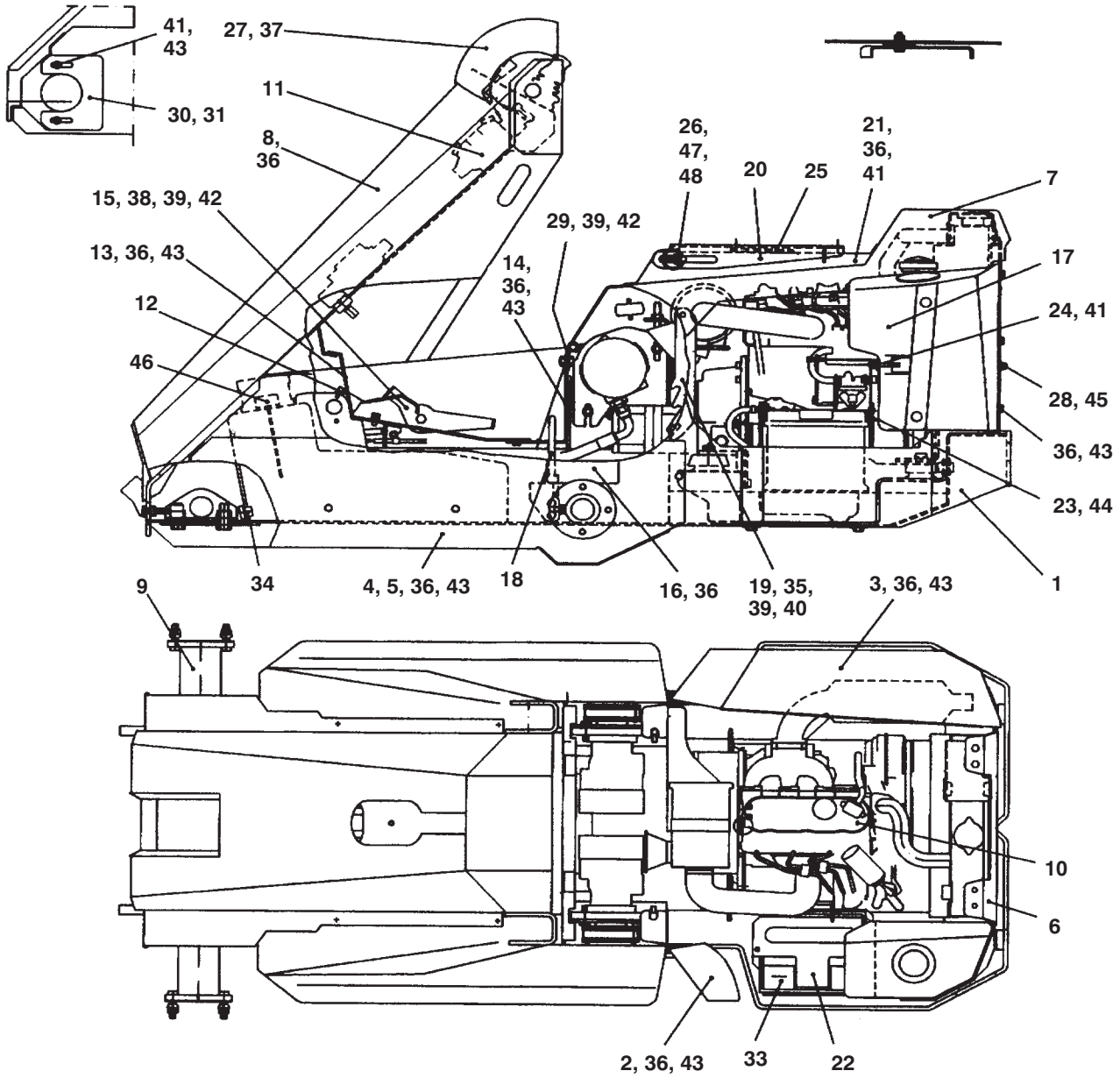

RL20DX - FRAME

Ref. No.	Part No.	Description	Qty. Req.	Ref. No.	Part No.	Description	Qty. Req.
01	155295	FRAME	1	25	154972	HANDLE/SEAT LOCKING	1
02	155356	PLATE/COVER LT	1	26	155000	PIN/PIVOT SEAT	1
03	155357	PLATE/COVER RT	1	27	154986	COVER/FINGER PROTECTING	1
04	155350	COVER/CHAIN LT	1	28	155128	ROD/SCREW	1
05	155351	COVER/CHAIN RT	1	29	155001	LOOP/HINGE	2
06	155346	FRAME/SUPPORT	1	30	155349	PLATE/SEAL REAR	2
07	155341	COVER	1	31	155348	PLATE/SEAL FRONT	2
08	155303	PLATE/COVER	1	32	155294	HARNESS/WIRE	1
09	155302	DRIVE/TRANSMISSION	1	33	154860	BATTERY/12V	1
10	155296	ENGINE	1	34	154942	PLUG/HEX 3/8"	1
11	155297	HYDRAULICS	1	35	154896	CS M10-30	1
12	155327	PEDAL/THROTTLE	1	36	154916	CS M8-16	30
13	155331	PLATE/BOTTOM FRONT	1	37	154886	CS M6-12	4
14	155347	PLATE/BOTTOM REAR	1	38	155358	WASHER/RUBBER	1
15	155355	LEVER/THROTTLE PEDAL LOCKING ..	1	39	154909	LN M10	4
16	155052	PLATE/COVER WHEEL HUB	2	40	154908	HN M10	1
17	155354	TANK/FUEL	1	41	154904	HN M8	10
18	155301	BRAKE/PARKING	1	42	155289	WASHER M10	1
19	155339	LEVER/SUPPORT	1	43	154922	WASHER M8	30
20	154971	BASE/SEAT	1	44	154901	HN M6	2
21	155332	PLATE/SEAT SUPPORT	1	45	155290	NUT/BOX M8	1
22	155335	PLATE/BATTERY HOLDING	1	46	154992	BREATHER/DIPSTICK	1
23	155345	CLAMP/BATTERY SUPPORT	2	47	154924	WASHER M12	1
24	155127	SUPPORT	1	48	154880	SPLINT/RING	1

RL20DX - ENGINE

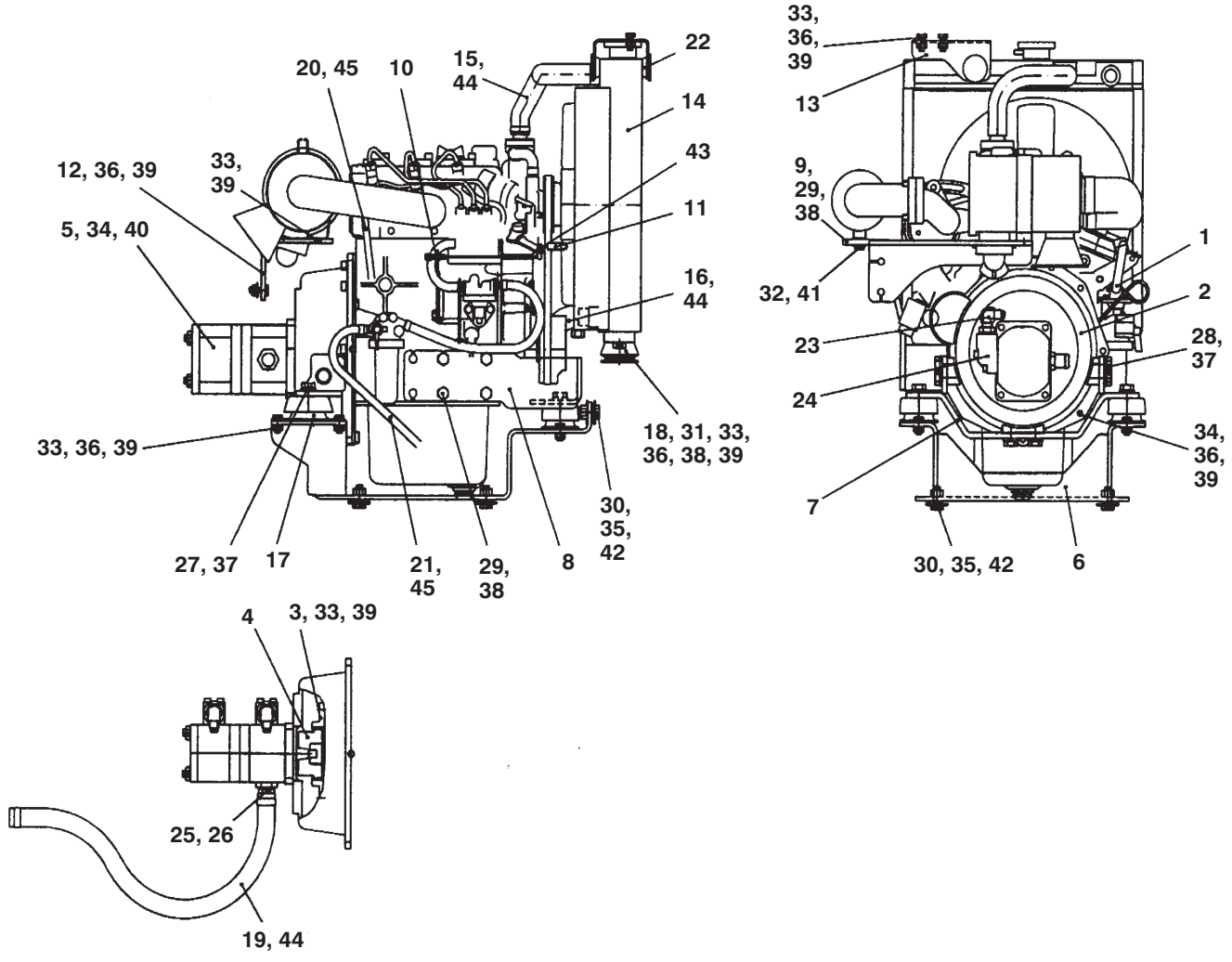

RL20DX - ENGINE

Ref. No.	Part No.	Description	Qty. Req.	Ref. No.	Part No.	Description	Qty. Req.
01	155279	ENGINE/KUBOTA	1	24	154933	FLANGE/PRESSURE	2
02	154869	HOUSING/COUPLING	1	25	154811	COUPLING/HOSE	1
03	154871	COUPLING	1	26	154835	REDUCER	1
04	154873	COUPLING	1	27	154917	CS M12-35	3
05	155280	PUMP/HYDRAULIC	1	28	154897	CS M12-20	6
06	155136	CRADLE/ENGINE	1	29	154936	CS M10-1,25	8
07	155134	FIXTURE/ENGINE LIFTING REAR	1	30	154895	CS M10-25	6
08	155135	FIXTURE/ENGINE LIFTING FRONT	1	31	155284	CS M10-16	2
09	155137	SUPPORT/EXHAUST PIPE	1	32	154891	CS M8-25	1
10	155003	EAR/THROTTLE WIRE	1	33	154890	CS M8-20	15
11	155138	SPRING/THROTTLE RETRACTING	1	34	154918	CS M8-30	10
12	155334	HOLDER/AIR CLEANER	1	35	154909	LN M10	6
13	155340	EAR/RADIATOR UPPER	1	36	154904	LN M8	16
14	155359	RADIATOR	1	37	154931	WASHER M12	6
15	155336	HOSE/WATER UPPER	1	38	154930	WASHER M10	8
16	155329	HOSE/WATER LOWER	1	39	154938	WASHER M8	25
17	154781	DAMPER/VIBRATION	3	40	154876	WASHER M8	4
18	155274	DAMPER/VIBRATION	2	41	154877	WASHER M8	2
19	155076	HOSE/INLET	1	42	154915	WASHER M10	6
20	155077	HOSE/FUEL INLET	1	43	154944	NIPPLE/SCREW	1
21	155078	HOSE/FUEL RETURN	1	44	154927	CLAMP/HOSE	5
23	154789	FITTING/ELBOW 90°	2	45	154941	CLAMP/HOSE	4

RL20DX - LOADER BOOM

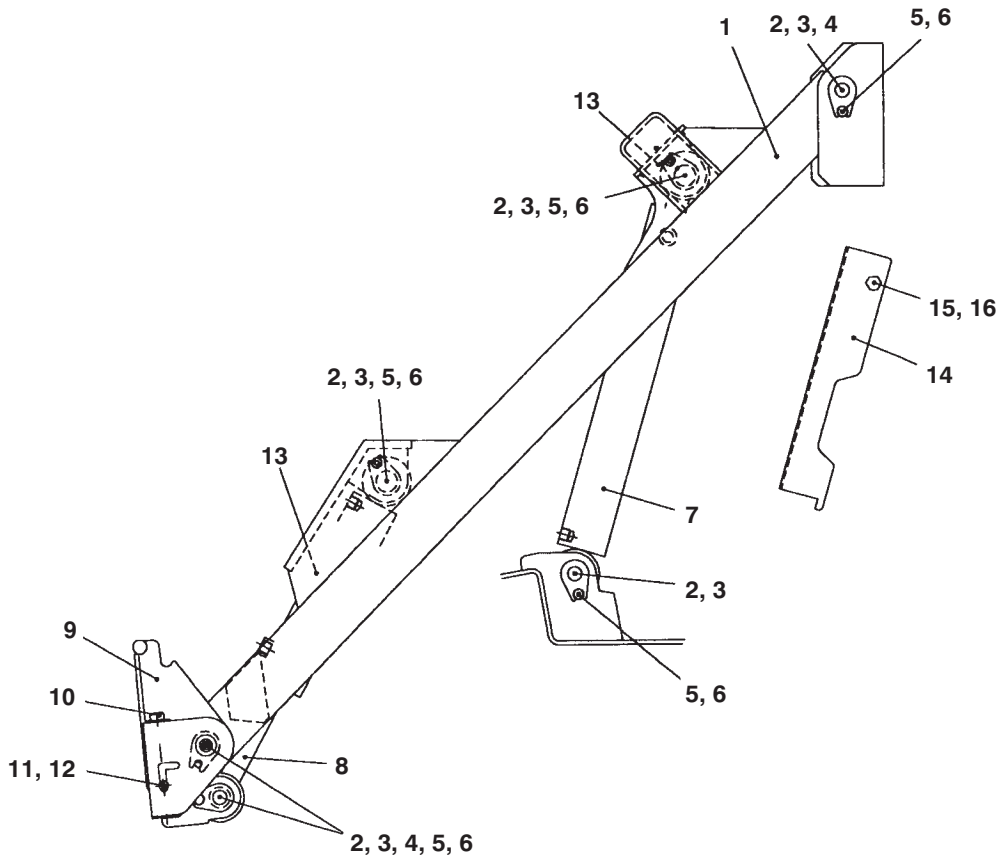

Ref. No.	Part No.	Description	Qty. Req.	Ref. No.	Part No.	Description	Qty. Req.
01	154956	BOOM/LOADER	1	09	154957	PLATE/ATTACHMENT	1
02	154993	PIN/PIVOT	8	10	154997	PIN/QUICK COUPLING	2
03	154914	FITTING/R1/8" STRAIGHT	8	11	154943	CS M8-80	2
04	154790	BEARING/SLIDE	4	12	154794	SPRING/PRESSURE	2
05	154916	CS M8-16	8	13	154934	CLAMP/PIPE	2
06	154938	WASHER/SPRING M8	8	14	154989	BOOM/SERVICE SUPPORT	1
07	154990	CYLINDER/HYDRAULIC	1	15	154899	CS M12-60	1
08	154991	CYLINDER/HYDRAULIC	1	16	154910	HN M12	1

RL20DX - TRANSMISSION

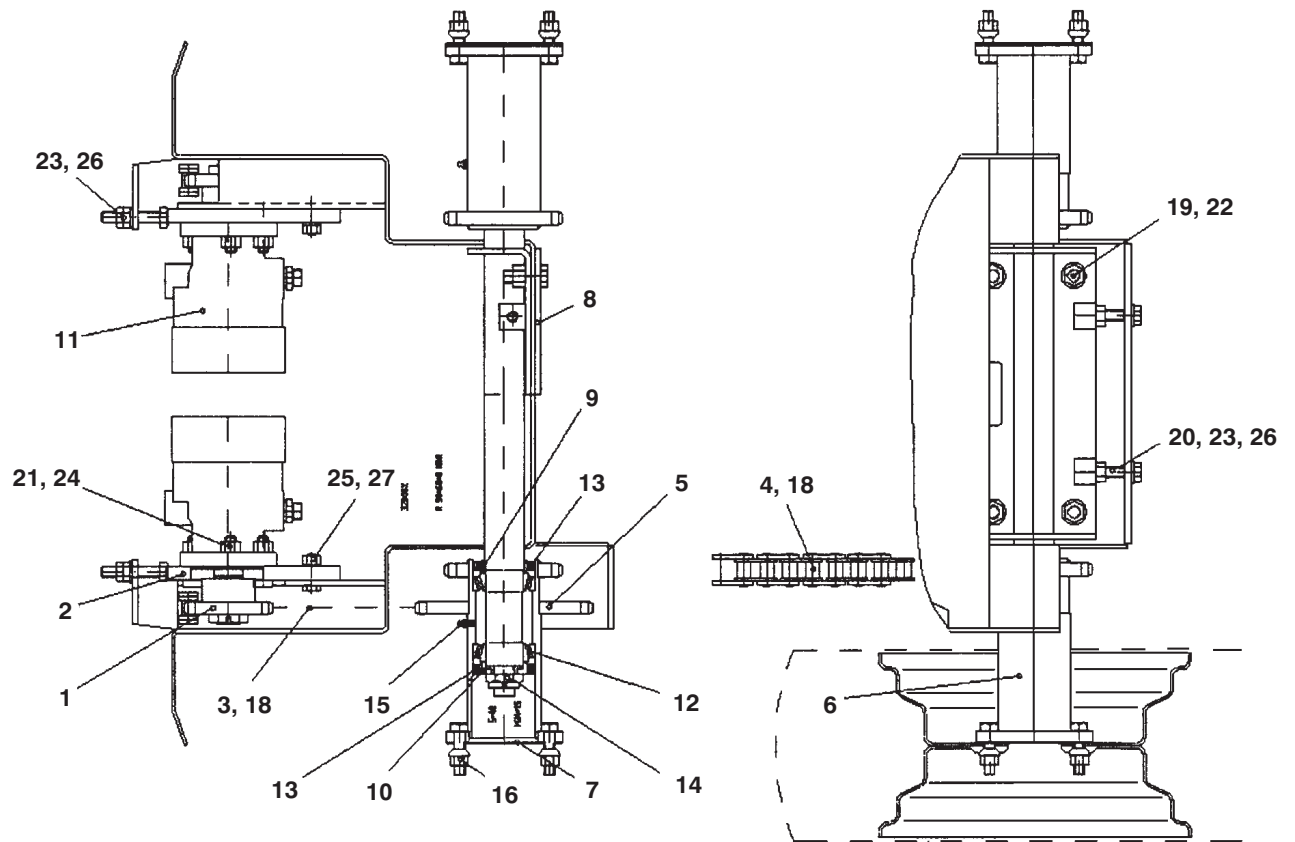

Ref. No.	Part No.	Description	Qty. Req.	Ref. No.	Part No.	Description	Qty. Req.
01	155106	WHEEL/CHAIN PRIMARY	2	14	155292	LN M24-1,5	4
02	155342	CARRIER	2	15	155286	NIPPLE/GREASE M6	4
03	155360	CHAIN/TRANSMISSION PRIMARY ...	2	16	154932	NUT/WHEEL M12-1,5	16
04	155368	CHAIN/TRANSMISSION SECONDARY .	2	18	154929	LINK/CONNECTING	4
05	155344	HUB/WHEEL BACK	2	19	155285	CS M14-40	4
06	155343	HUB/WHEEL FRONT	2	20	154925	CS M12-60	2
07	155333	SPACER/HUB	4	21	154898	CS M12-45	8
08	155309	COUNTERPLATE	1	22	155378	LN M14	4
09	155337	RING/SLIDE	4	23	154910	LN M12	6
10	155338	RING/SUPPORT	4	24	154911	LN M12	8
11	154863	MOTOR/HYDRAULIC	2	25	154909	LN M10	6
12	155278	BEARING/CONICAL ROLLER	8	26	154924	WASHER M12	4
13	155277	GASKET	8	27	154919	WASHER M10	6

RL20DX - FOOT THROTTLE

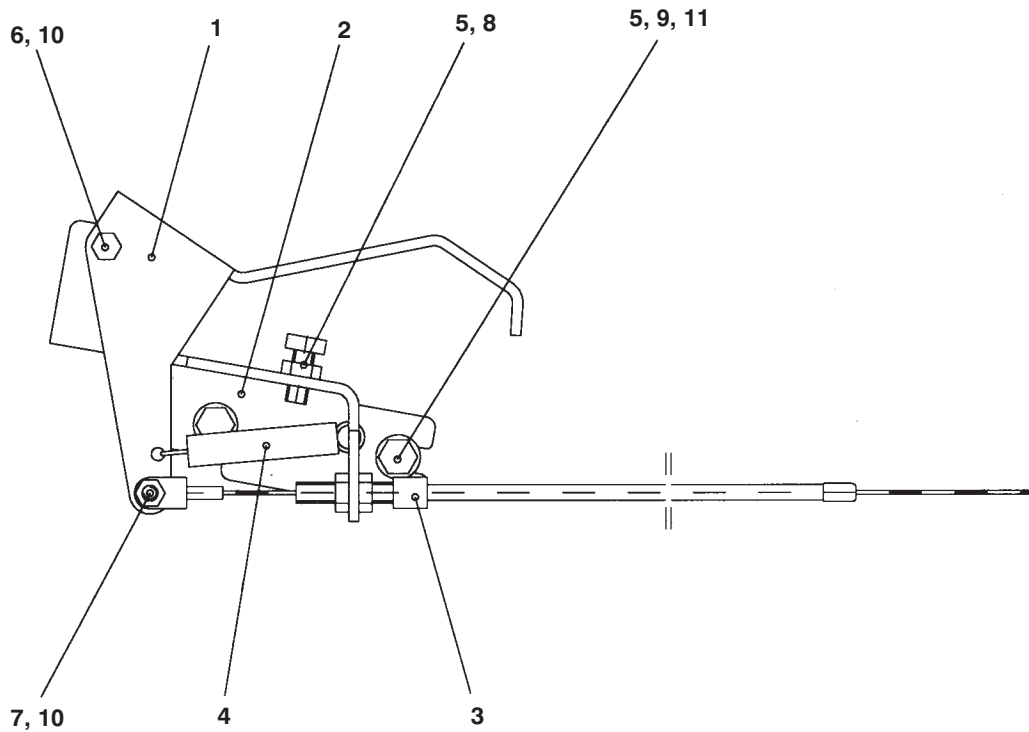

Ref. No.	Part No.	Description	Qty. Req.	Ref. No.	Part No.	Description	Qty. Req.
01	155005	PEDAL/THROTTLE	1	07	154887	CS M6-20	1
02	155326	FRAME/THROTTLE PEDAL	1	08	154903	HN M8	1
03	155328	WIRE/THROTTLE	1	09	154904	LN M8	2
04	154864	SPRING/RETAINING	1	10	154902	LN M6	2
05	154890	CS M8-20	3	11	154923	WASHER M6	2
06	154888	CS M6-90	1				

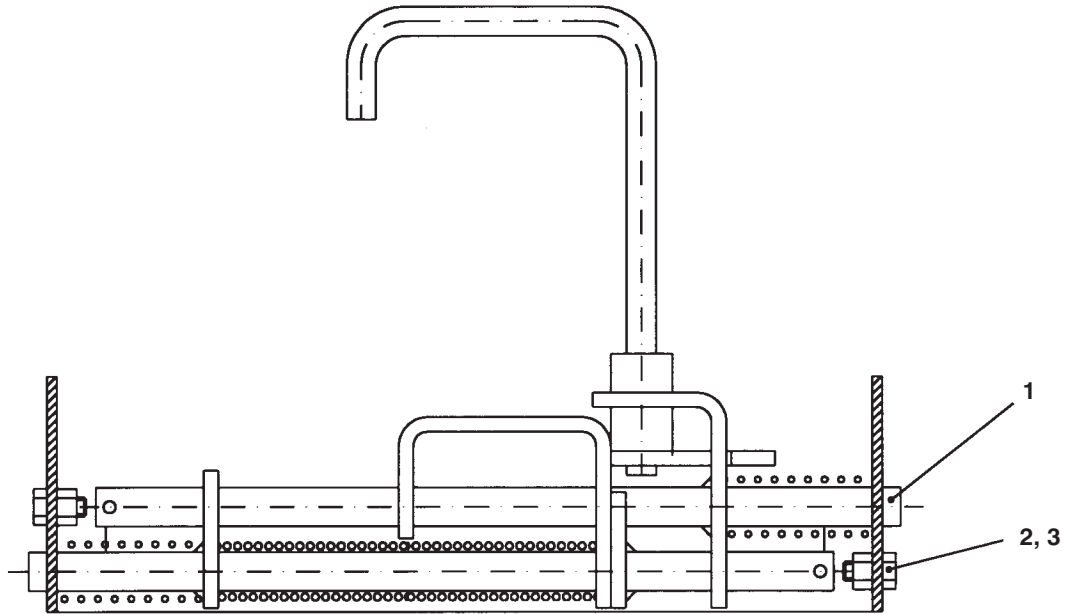

Ref. No.	Part No.	Description	Qty. Req.
01	155305	BRAKE/PARKING	1
02	154916	CS M8-16	2
03	154904	LN M8	2

RL20DX - HYDRAULICS

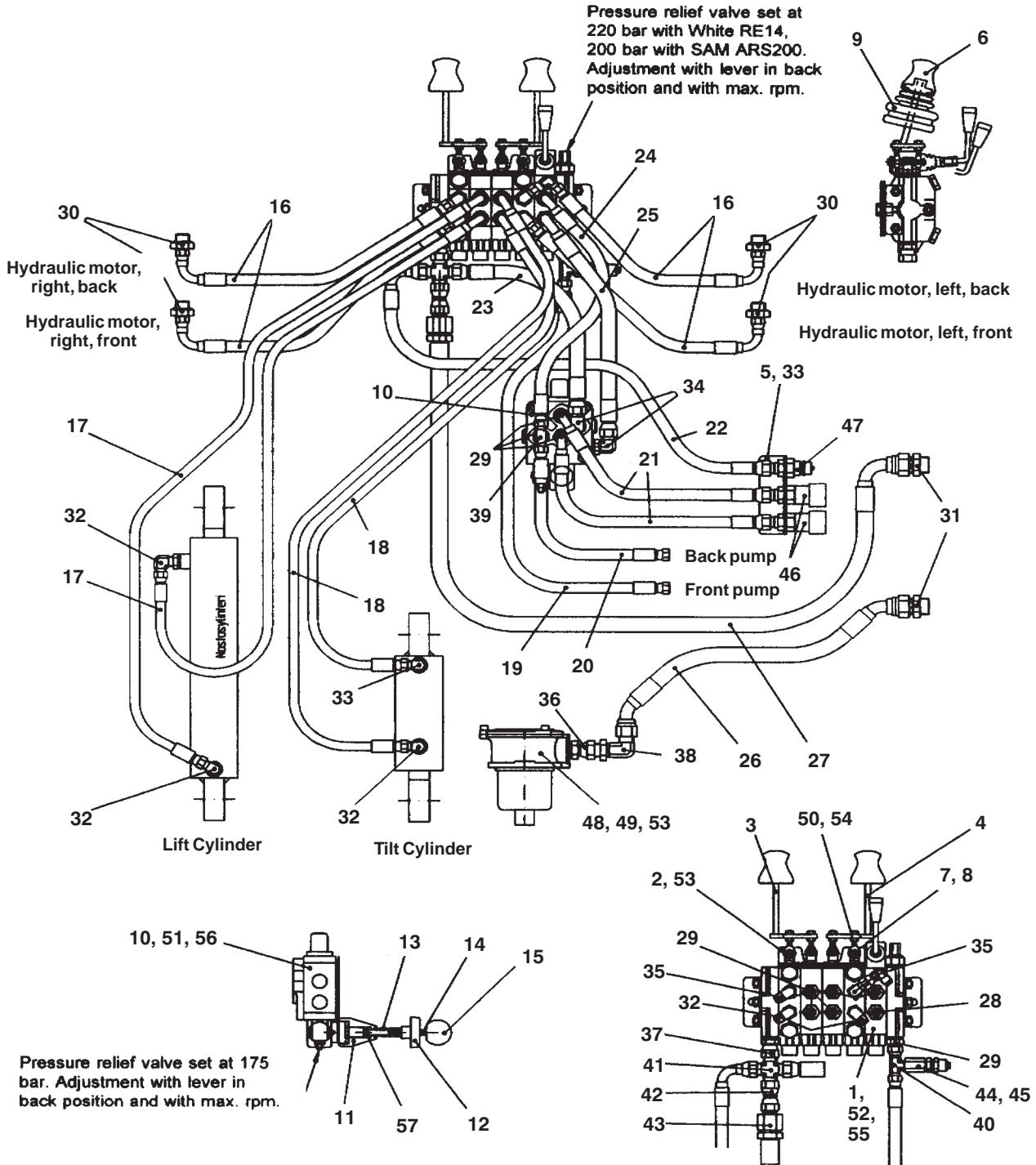

RL20D, RL20DX - HYDRAULICS

Ref. No.	Part No.	Description	Qty. Req.	Ref. No.	Part No.	Description	Qty. Req.
01	155276	VALVE/CONTROL	1	30	154785	FITTING/BASIC	4
02	155306	FRAME/CONTROL LEVER	1	31	155265	FITTING/BASIC	2
03	155308	LEVER/CONTROL RT	1	32	154789	FITTING/ELBOW 90°	6
04	155307	LEVER/CONTROL LT	1	33	154812	FITTING/ELBOW 90°	1
05	155316	SUPPORT/QUICK COUPLING	1	34	155262	FITTING/ELBOW 90°	2
06	155352	KNOB	2	35	154788	FITTING/ELBOW 90°	3
07	154998	PIN/CONTROL LEVER	4	36	155267	NIPPLE/CONNECTOR	1
08	154999	NUT/LEVER M6	8	37	155264	NIPPLE/CONNECTOR	1
09	154940	COVER/RUBBER	2	38	155268	FITTING/ELBOW LEAD-THROUGH	1
10	155261	VALVE/DIRECTIONAL	1	39	155263	FITTING/TEE THREADED	1
11	155362	BUSHING/LOCKING	1	40	154796	BODY/L FITTING	1
12	155271	SCREW/FINGER	1	41	154797	FITTING/CROSS	1
13	155273	SPRING/PRESSURE	1	42	155269	NIPPLE/O	1
14	155363	LEVER/CONTROL	1	43	154802	REDUCER	1
15	154912	KNOB/BALL	1	44	154856	FITTING/TEST	1
16	155310	HOSE/HYDRAULIC L=1400	4	45	154857	FITTING/MANOMETER	1
17	155314	HOSE/HYDRAULIC L=720	2	46	154851	COUPLER/QUICK FEMALE	2
18	155315	HOSE/HYDRAULIC L=3100	2	47	154850	COUPLER/QUICK MALE	1
19	155311	HOSE/HYDRAULIC L=1430	1	48	155287	FILTER/OIL HYDRAULIC	1
20	155321	HOSE/HYDRAULIC L=1150	1	49	154939	FILTER	1
21	155320	HOSE/HYDRAULIC L=1400	2	50	154782	ARM/JOINT	6
22	155323	HOSE/HYDRAULIC L=1950	1	51	155283	CS M8-60	3
23	155322	HOSE/HYDRAULIC L=370	1	52	154895	CS M10-25	2
24	155319	HOSE/HYDRAULIC L=400	1	53	155282	CS M8-25	4
25	155318	HOSE/HYDRAULIC L=400	1	54	155288	CS M6-16	4
26	155324	HOSE/HYDRAULIC L=1420	1	55	154909	LN M10	2
27	155325	HOSE/HYDRAULIC L=2200	1	56	154904	LN M8	1
28	154787	FITTING/BASIC	1	57	154903	HN M8	1
29	154786	FITTING/BASIC	12				

Index

D

Decal Locations, 2–3

E

Engine

RL14D, 10–11

RL20D, 12–13

RL20DX, 12–13

F

Foot Throttle, 18

Frame

RL14D, 6–7

RL20D, 8–9

RL20DX, 8–9

Frame, Seat, Wheel & Boom

RL14D, 5

RL20D, 5

RL20DX, 5

H

Hydraulics

RL14D, 20–21

RL20D, RL20DX, 22–23

L

Loader Boom, 14–15

P

Parking Brake, 19

T

Transmission

RL14D, 15

RL20D, 16

RL20DX, 17

RL20DX - NUMERICAL INDEX

Part No.	Page No.	Ref. No.	Part No.	Page No.	Ref. No.	Part No.	Page No.	Ref. No.	Part No.	Page No.	Ref. No.
L65922	02	01	154860	07	33	154904	07	41	154924	17	26
093367	02	03	154860	09	33	154904	09	41	154925	15	20
093474	02	04	154861	21	23	154904	11	28	154925	16	20
093476	02	05	154863	17	11	154904	13	36	154925	17	20
114316	02	06	154864	18	04	154904	18	09	154927	11	36
122718	02	07	154869	11	02	154904	19	03	154927	13	44
129132	02	08	154869	13	02	154904	23	56	154929	15	18
132139	02	09	154871	11	03	154908	07	40	154929	16	18
145216	02	10	154871	13	03	154908	09	40	154929	17	18
154781	11	15	154873	11	04	154909	07	39	154930	11	30
154781	13	17	154873	13	04	154909	09	39	154930	13	38
154782	21	33	154876	11	32	154909	11	27	154931	11	29
154782	23	50	154876	13	40	154909	13	35	154931	13	37
154785	21	18	154877	07	50	154909	17	25	154932	15	16
154785	23	30	154877	11	34	154909	21	37	154932	16	16
154786	21	17	154877	13	41	154909	23	55	154932	17	16
154786	23	29	154880	07	48	154910	14	16	154933	11	17
154787	23	28	154880	09	48	154910	15	23	154933	13	24
154788	23	35	154884	16	27	154910	16	23	154934	14	13
154789	11	16	154886	07	37	154910	17	23	154936	11	22
154789	13	23	154886	09	37	154911	15	24	154936	13	29
154789	21	19	154887	18	07	154911	16	24	154938	11	33
154789	23	32	154888	18	06	154911	17	24	154938	13	39
154790	14	04	154890	11	25	154912	23	15	154938	14	06
154794	14	12	154890	13	33	154914	14	03	154939	21	30
154796	23	40	154890	18	05	154915	11	31	154939	23	49
154797	23	41	154891	11	24	154915	13	42	154940	21	09
154801	15	11	154891	13	32	154916	05	05	154940	23	09
154802	23	43	154895	11	23	154916	07	36	154941	11	37
154807	05	02	154895	13	30	154916	09	36	154941	13	45
154811	11	18	154895	21	36	154916	14	05	154942	07	34
154811	13	25	154895	23	52	154916	15	27	154942	09	34
154812	21	20	154896	07	35	154916	19	02	154943	14	11
154812	23	33	154896	09	35	154917	11	20	154944	11	35
154815	05	03	154897	11	21	154917	13	27	154944	13	43
154835	11	19	154897	13	28	154917	13	27	154956	14	01
154835	13	26	154898	15	21	154918	11	26	154957	14	09
154846	11	01	154898	16	21	154918	13	34	154958	05	04
154850	21	27	154898	17	21	154919	17	27	154971	07	20
154850	23	47	154899	14	15	154922	05	06	154971	09	20
154851	21	28	154901	07	44	154922	07	43	154972	07	25
154851	23	46	154901	09	44	154922	09	43	154972	09	25
154856	21	25	154901	21	38	154923	18	11	154972	09	25
154856	23	44	154901	09	44	154923	18	11	154986	07	27
154856	23	44	154902	18	10	154924	07	47	154986	07	27
154857	21	26	154903	18	08	154924	09	47	154989	09	27
154857	23	45	154903	23	57	154924	09	47	154989	14	14
									154990	14	07
									154991	14	08

RL20DX - NUMERICAL INDEX

Part No.	Page No.	Ref. No.	Part No.	Page No.	Ref. No.	Part No.	Page No.	Ref. No.	Part No.	Page No.	Ref. No.
154992	07	46	155264	23	37	155295	07	01	155326	18	02
154992	09	46	155265	23	31	155295	09	01	155327	07	12
154993	14	02	155266	21	05	155296	09	10	155327	09	12
154994	15	01	155267	23	36	155297	07	11	155328	18	03
154996	15	26	155268	23	38	155297	09	11	155329	13	16
154997	14	10	155269	23	42	155298	05	01	155331	07	13
154998	21	31	155270	05	03	155299	05	01	155331	09	13
154998	23	07	155271	23	12	155300	07	10	155332	07	21
154999	21	32	155272	16	11	155301	07	18	155332	09	21
154999	23	08	155273	23	13	155301	09	18	155333	15	07
155000	07	26	155274	13	18	155302	09	09	155333	16	07
155000	09	26	155275	07	49	155303	07	08	155333	17	07
155001	07	29	155276	23	01	155303	09	08	155334	13	12
155001	09	29	155277	15	13	155304	07	09	155335	07	22
155003	11	10	155277	16	13	155305	19	01	155335	09	22
155003	13	10	155277	17	13	155306	21	02	155336	13	15
155005	18	01	155278	15	12	155306	23	02	155337	15	09
155052	07	16	155278	16	12	155307	21	04	155337	16	09
155052	09	16	155278	17	12	155307	23	04	155337	17	09
155076	11	12	155279	13	01	155308	21	03	155338	15	10
155076	13	19	155280	11	05	155308	23	03	155338	16	10
155077	11	14	155280	13	05	155309	15	08	155338	17	10
155077	13	20	155281	21	01	155309	16	08	155339	07	19
155078	11	13	155282	21	35	155309	17	08	155339	09	19
155078	13	21	155282	23	53	155310	21	10	155340	13	13
155106	17	01	155283	23	51	155310	23	16	155341	07	07
155115	11	39	155284	13	31	155311	21	11	155341	09	07
155127	07	24	155285	15	19	155311	23	19	155342	17	02
155127	09	24	155285	16	19	155312	21	12	155343	15	06
155128	07	28	155285	17	19	155313	21	16	155343	16	06
155128	09	28	155286	15	15	155314	21	15	155343	17	06
155134	11	07	155286	16	15	155314	21	15	155344	15	05
155134	13	07	155286	17	15	155314	23	17	155344	16	05
155135	11	08	155287	21	29	155315	21	14	155344	17	05
155135	13	08	155287	23	48	155315	23	18	155345	07	23
155136	13	06	155288	23	54	155316	21	08	155345	09	23
155137	11	09	155289	07	42	155316	23	05	155346	07	06
155137	13	09	155289	09	42	155317	21	06	155346	09	06
155138	11	11	155290	07	45	155318	21	06	155346	09	06
155138	13	11	155290	09	45	155318	23	25	155347	07	14
155260	21	21	155291	21	34	155319	23	24	155347	09	14
155261	23	10	155292	15	14	155320	23	21	155348	07	31
155262	23	34	155292	16	14	155321	23	20	155348	09	31
155263	21	24	155292	17	14	155322	23	23	155348	09	31
155263	23	39	155294	07	32	155323	23	23	155349	07	30
155264	21	22	155294	09	32	155323	21	13	155349	09	30
						155323	23	22	155350	07	04
						155324	23	26	155350	09	04
						155325	23	27	155351	07	05

RL20DX - NUMERICAL INDEX







Part No.	Page No.	Ref. No.	Part No.	Page No.	Ref. No.	Part No.	Page No.	Ref. No.	Part No.	Page No.	Ref. No.
155351	09	05	155357	07	03	155363	23	14	155378	17	22
155352	21	07	155357	09	03	155364	16	01	155724	02	11
155352	23	06	155358	07	38	155365	16	26	155725	02	13
155353	11	06	155358	09	38	155366	11	38	155726	02	13
155354	07	17	155359	13	14	155367	15	02	155728	02	13
155354	09	17	155360	15	03	155368	15	04	155729	02	12
155355	07	15	155360	16	03	155368	16	04	156137	02	14
155355	09	15	155360	17	03	155368	17	04	156306	02	02
155356	07	02	155361	16	02	155378	15	22	156320	05	07
155356	09	02	155362	23	11	155378	16	22	156321	05	08

NOTES

TORQUE SPECIFICATIONS

NOTE: Use these torque values when tightening **GEHL** hardware (excluding: Locknuts and Self-tapping, Thread Forming and Sheet Metal Screws) unless specified otherwise.

All torque values are in Lb-Ft except those marked with an * which are Lb-In
(For metric torque value Nm, multiply Lb-Ft value by 1.355 or Lb-In value by 0.113)

Unified National Thread	Grade 2 		Grade 5 		Grade 8 	
	Dry	Lubed	Dry	Lubed	Dry	Lubed
8-32	19*	14*	30*	22*	41*	31*
8-36	20*	15*	31*	23*	43*	32*
10-24	27*	21*	43*	32*	60*	45*
10-32	31*	23*	49*	36*	68*	51*
1/4-20	66*	50*	9	75*	12	9
1/4-28	76*	56*	10	86*	14	10
5/16-18	11	9	17	13	25	18
5/16-24	12		19	14		20
3/8-16	20	15	30	23	45	35
3/8-24	23	17	35	25	50	
7/16-14	32	24	50	35	70	55
7/16-20	36	27	55	40	80	60
1/2-13	50	35	75	55	110	80
1/2-20	55	40	90	65	120	90
9/16-12	70	55	110	80	150	110
9/16-18	80	60	120	90	170	130
5/8-11	100	75	150	110	220	170
5/8-18	110	85	180	130	240	180
3/4-10	175	130	260	200	380	280
3/4-16	200	150	300	220	420	320
7/8-9	170	125	430	320	600	460
7/8-14	180	140	470	360	660	500
1-8	250	190	640	480	900	680
1-14	270	210	710	530	1000	740
Metric Course Thread	Grade 8.8 		Grade 10.9 		Grade 12.9 	
	Dry	Lubed	Dry	Lubed	Dry	Lubed
M6-1	8	6	11	8	13.5	10
M8-1.25	19	14	27	20	32.5	24
M10-1.5	37.5	28	53	39	64	47
M12-1.75	65	48	91.5	67.5	111.5	82
M14-2	103.5	76.5	145.5	108	176.5	131
M16-2	158.5	117.5	223.5	165.5	271	200

GEHL®

Gehl Company 143 Water Street, P.O. Box 179, West Bend, WI 53095-0179, U.S.A.